

ADD
YOUR
OWN
DOODLES!

this ACTIVITY BOOK

BELONGS



KESEM NAME HERE

WELCOME TO THE KESEM AT HOME

≡activity book≡

Containing over 50 activities for children of all ages! Although most activities in this book can be completed by the entire family, the following pages are sorted by increasing difficulty. Each activity is designed to capture the essence and magic of the Kesem community; some you may recognize, and others are unique to Kesem.

Take this activity book with you everywhere you go! Whether you are in your home, at the park, or in the car, this collection of activities will keep you busy for hours—with few supplies needed! As you dig into the pages following, remember that your Kesem community—complete with thousands of campers, counselors, and supporters across the country—is always under the same moon and stars.

ACKNOWLEDGEMENTS

Just as Kesem at Home would not be possible without incredible student leaders all across the country, the creation of this Camp Kesem Activity Book would not have been possible without the contributions of our Camp Kesem National interns, who showed incredible flexibility, resilience, and service to our mission in light of extraordinary circumstances. Thank you each for your thoughtful contributions during Kesem's 20th Anniversary!

Isabella Basche Camp Kesem at Chapman University

Logan Dechter Camp Kesem at University of Maryland

Divya Jain Camp Kesem Berkeley

Gabriel Kardia Camp Kesem at The University of Michigan

Tal Richter Camp Kesem at UC Santa Barbara

SECRET MESSAGE

Constellations tell us stories in the sky. Can you trace the dots and find out the secret message below?

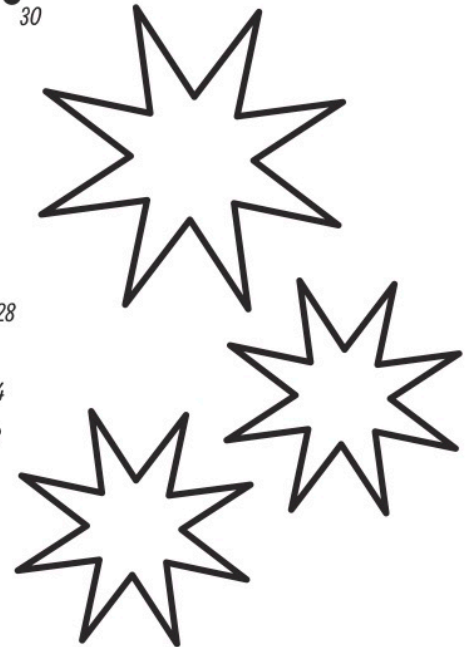
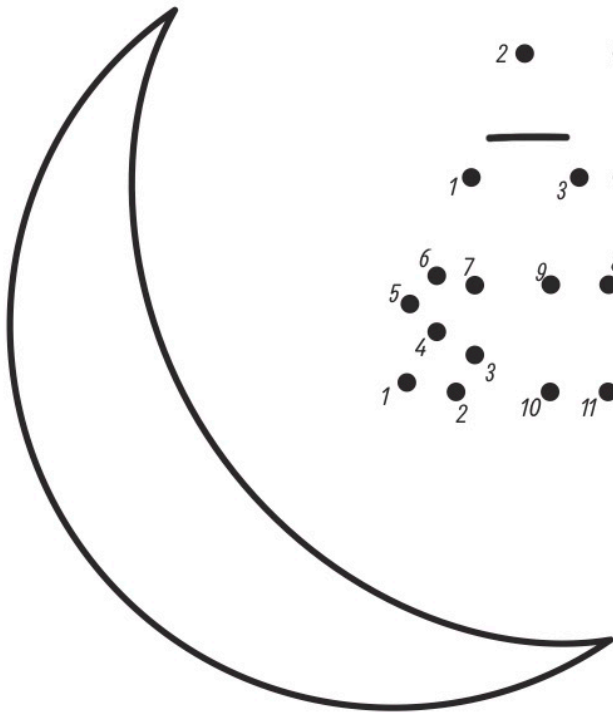
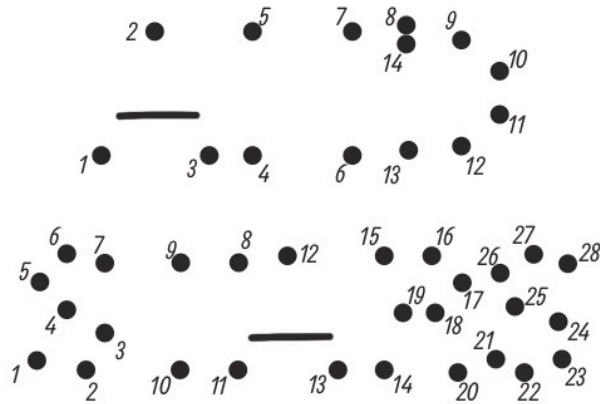
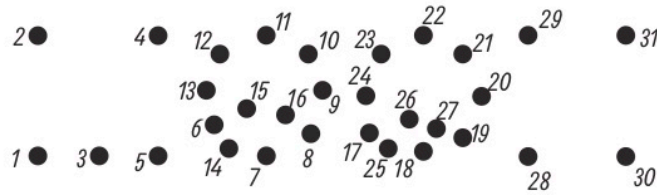
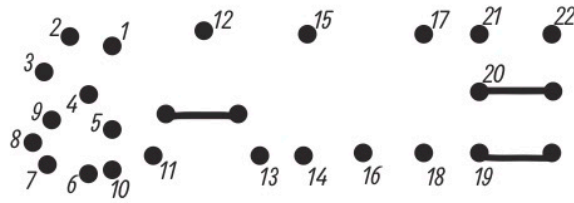
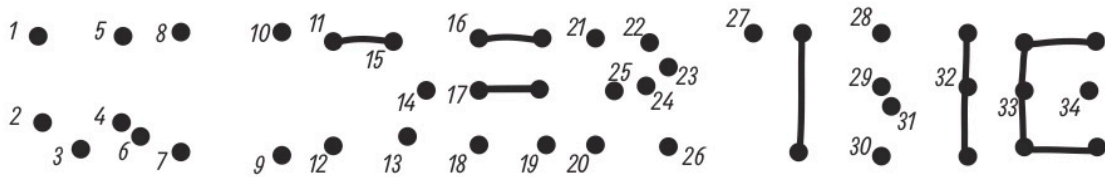











DECORATE YOUR CABIN



Design and style your dream cabin to get it ready for camp!



I SPY!

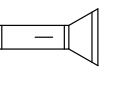

- 6 
- 8 
- 10 
- 6 
- 7 

- 9 
- 6 
- 8 
- 10 
- 9 

SPOT THE DIFFERENCE

Can you find 10 differences between these two pictures?

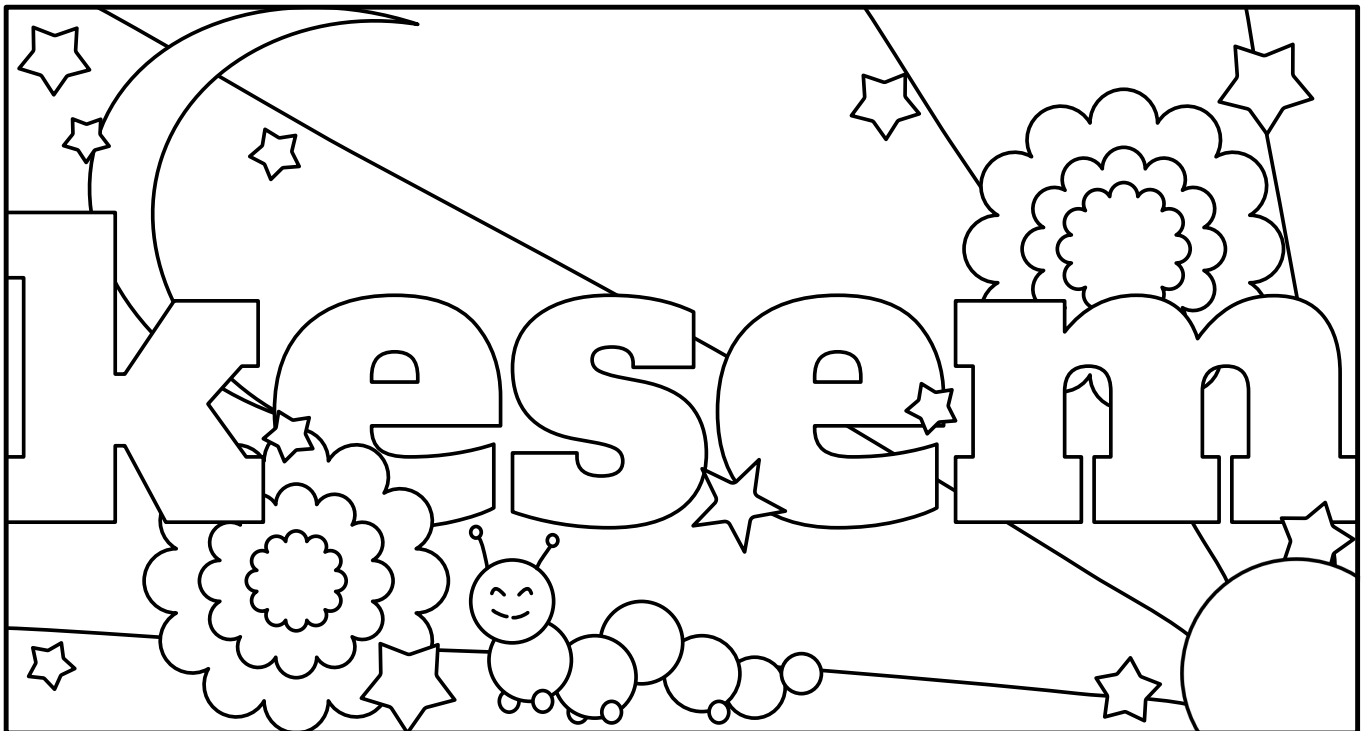

SECRET MESSAGE DECODER

Description: Use the provided code key to decode the secret message!

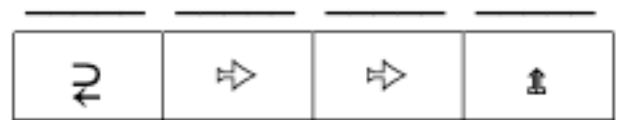
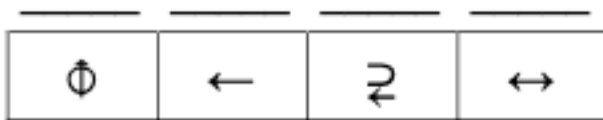
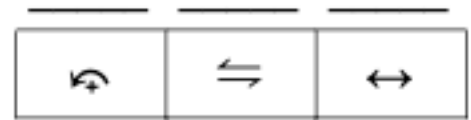

Code Key												
A	B	C	D	E	F	G	H	I	J	K	L	M
←	↑	→	↓	↕	↕	+	⇌	⌘	⇨	◆	●	↶
N	O	P	Q	R	S	T	U	V	W	X	Y	Z
↑	⇨	↺	↻	⇨	⊖	↺	▶	⌘	↑	⇩	↻	⊖

KARL MAZE

Follow the maze and collect the letters in each circle to complete the message!

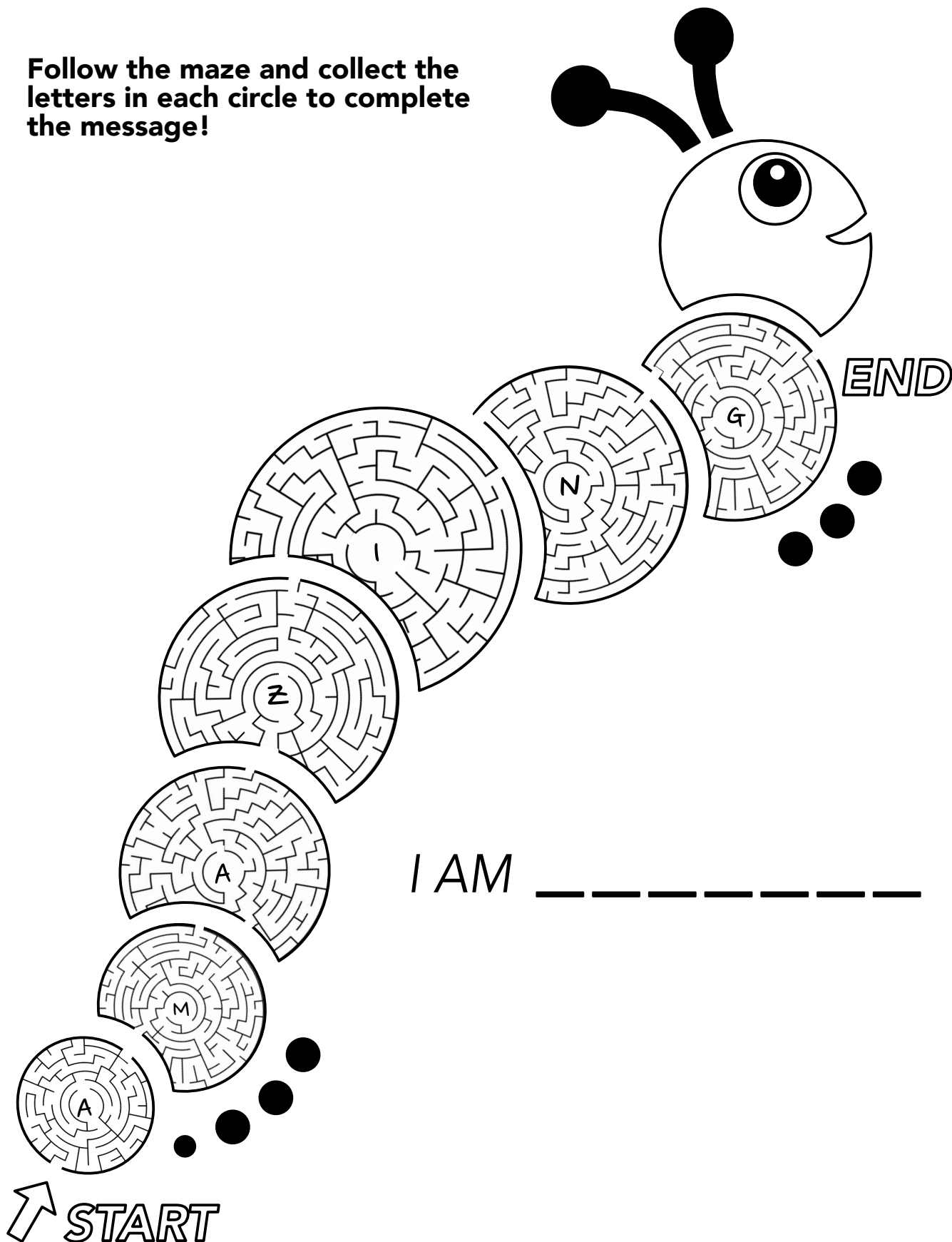

Help Karl go Kayaking at the Lake!

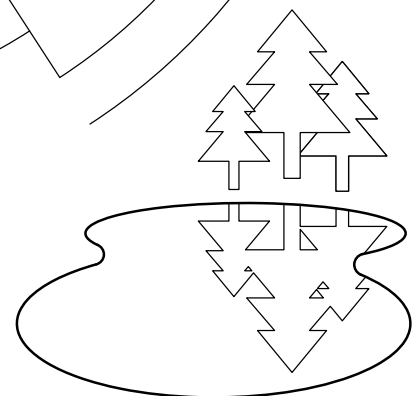
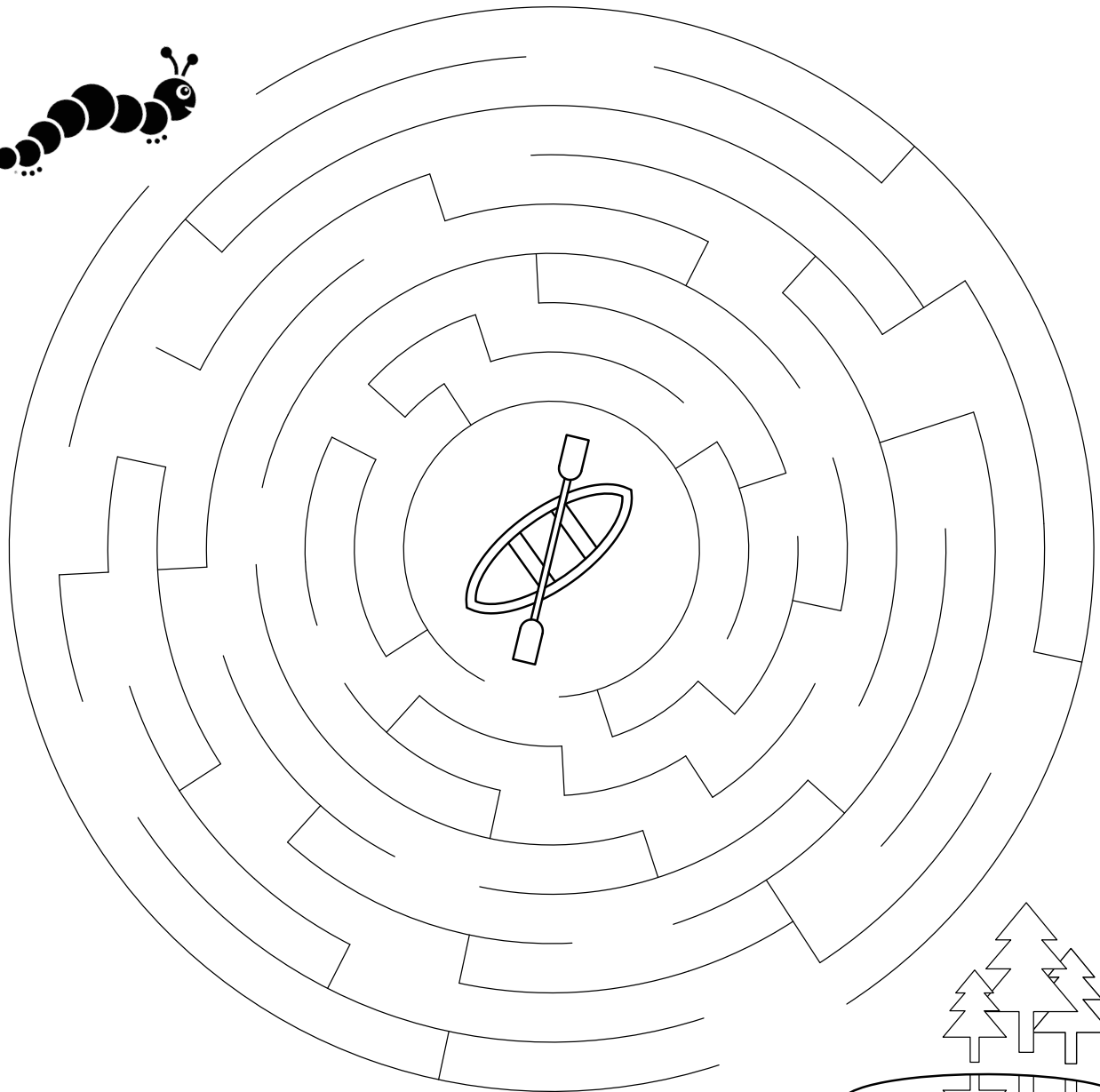

LEARN HOW TO DRAW KARL

Drawing Karl can be hard, but it's easier when you break it down into 7 simple steps.

- ① Begin by drawing a circle. Draw a faint horizontal line through its center with approximately the same space on either side.

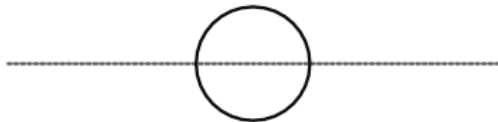

- ② On either side of the large circle, draw two smaller ones. Then draw two smaller circles on either side of those. Hint: the top of the far left circle should align with the guide line!

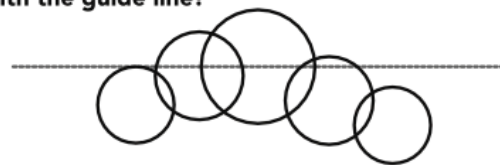

- ③ Draw a second faint guide line underneath the left circle - this will line up with the bottom of Karl's head!

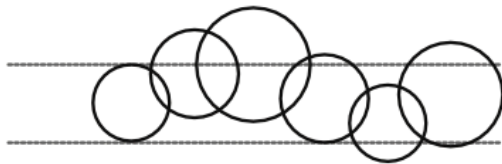

- ④ Halfway done! Draw two smaller circles at the left to complete Karl's tail. Don't forget the feet and antennae!

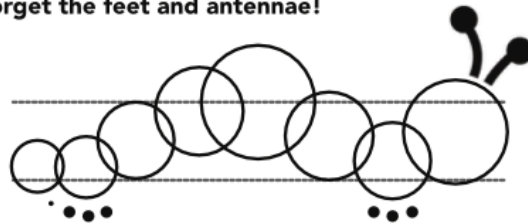

- ⑤ Karl needs a face now! The eye begins underneath our first guide line. Draw half of a crescent moon for his smile.

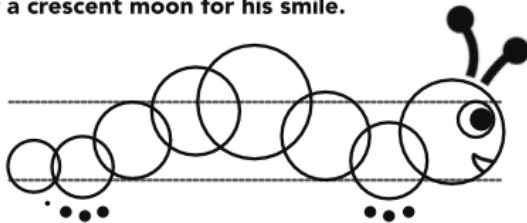

- ⑥ Almost to the finish line - carefully erase your horizontal lines! You can erase a dot in Karl's eye to add a sparkle, too!

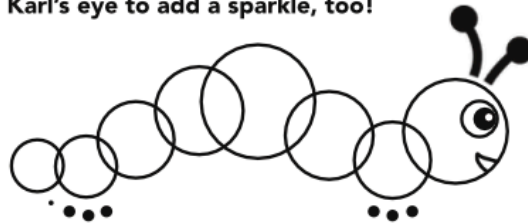

- ⑦ The last step: erase the overlapping areas of the circles, starting from Karl's head.

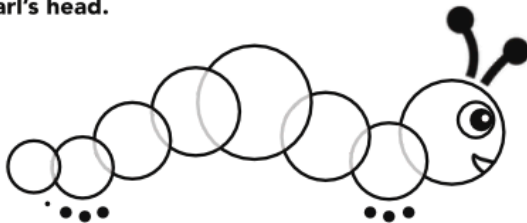

COMPLETE!

That's it! Now you can draw Karl everywhere!

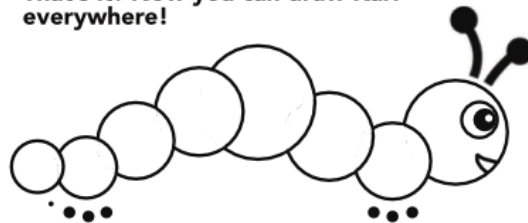

DOTS & BOXES

Description: In a grid below, take turns drawing a single horizontal or vertical line between two dots. The player who completes the fourth side of a box earns one point (marked by their initial in the box) and takes another turn. The game ends when no more lines can be placed. The winner of the game is the player with the most points.

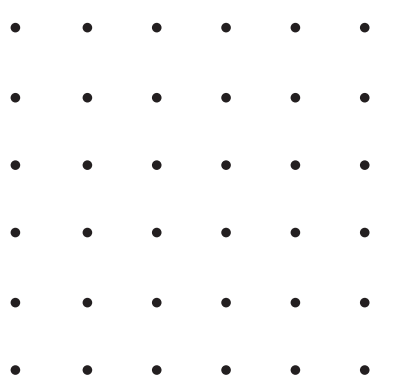
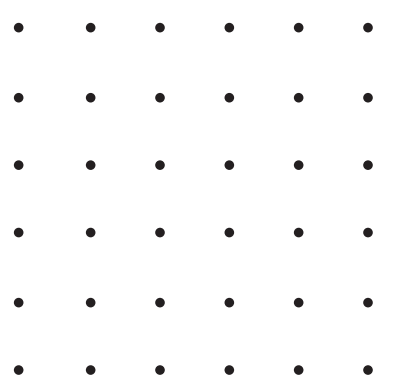
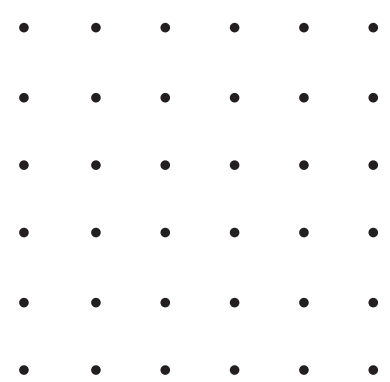
 <p>WINNER.....</p>	 <p>WINNER.....</p>	 <p>WINNER.....</p>
------------------------------------------------------------------------------------------------------	-------------------------------------------------------------------------------------------------------	--------------------------------------------------------------------------------------------------------

TIC-TAC-TOE

Description: The goal of Tic Tac Toe is to get three in a row. The first player is X and the second is O. Players alternate placing Xs and Os on the game board until either opponent has three in a row or all nine squares are filled. X always goes first, and if no one has three in a row, it is a “cat game”.

SCOREKEEPING

ROUND	WINNER
1	
2	
3	
4	
5	
6	
7	

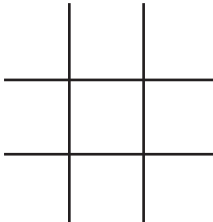
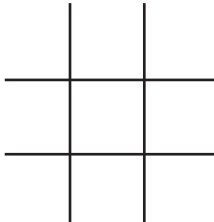
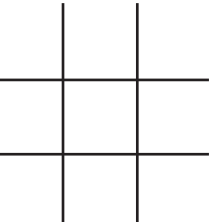
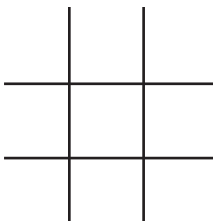
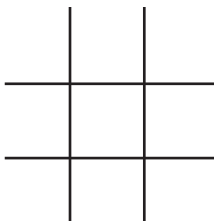
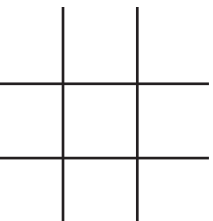
WORD SEARCH

Help Karl Get Ready for Camp!

S E E L T T O B R E T A W A
N J A U R P S O C K S L O O
P S S U N B L O C K T S A H
W R W S L E E P I N G B A G
A A K I Y I H L E W O T A O
T P N G M M B U G S P R A Y
C L A W L S K C A P K C A B
H K A J O W U R P T T H S A
C S T T A L W I H S A S H A
E S A Y R M L O T H E S O T
H H H P C B A I O I F W R C
T E K C A J A S P R W N T C
F L A S H L I G H T S A S T
M C P L W S R J O K S O B L

BACKPACK

PAJAMAS

SWIMSUIT

BUGSPRAY

PILLOW

TOWEL

FLASHLIGHT

SHORTS

TSHIRT

HAT

SLEEPING BAG

WATCH

JACKET

SUNBLOCK

WATER BOTTLE

WORD SEARCH *≡night at camp≡*

I C K X C Q M R B Q I R G X N
J A D V J B M V N K C P U W I
K B Z L V L W C R X X L O V Z
R I C R D C A M P F I R E F H
P N W J X G H V S M O R E S W
X G Y L S Y D T T F R A M U U
N Y M A R S H M A L L O W M F
E W Y N N X U K Z S T Z D M S
K G U Z I Q Q U E H C F F E X
A I N O E M X U W V Q R D R M
Q D X H O U K Q P V Y I L K M
W O I J O T O G E T H E R L Y
B G S Y K X R A S Z I N A L W
X N O S F W F C V Y K D I M I
N T N B C M X B U Y E S Y P J
N R G N K S Z L F O R E S T T

Word Bank:

Cabin Friends Smores Together
Campfire Hike Song
Forest Marshmallow Summer

WORD SEARCH

≡camp songs≡

F P L A N N H D W A J W W N Y
Y A Z W J M J H X Z M H Y C I
G F B U T T O N F A C T O R Y
B O A C O N S T R I C T O R J
G B V W A O W G Y V F V O K E
E H E Y B U R R I T O I U N T
T C A M P K E S E M C H E E R
L S T F Q B K A X G Q J D E D
O L I T T L E R E D W A G O N
O F C Y H W R Q Z C D M L X J
S D F L M F P P U I Z F V F H
E J Y U F P T A R Z A N H X Q
V V M Q A O S T I U I M T T R
R A Z Z L E D A Z Z L E U Z N
M B K E Q M C X E C T S N Z N

Word Bank:

Boa Constrictor

Get Loose

Razzle Dazzle

Button Factory

Hey Burrito

Tarzan

Camp Kesem Cheer

*Little Red
Wagon*



camp kesem.

My Camp Memories

Draw your favorite memories from previous year's of Camp Kesem or, at the end of the summer, draw your favorite memories from Kesem at Home!

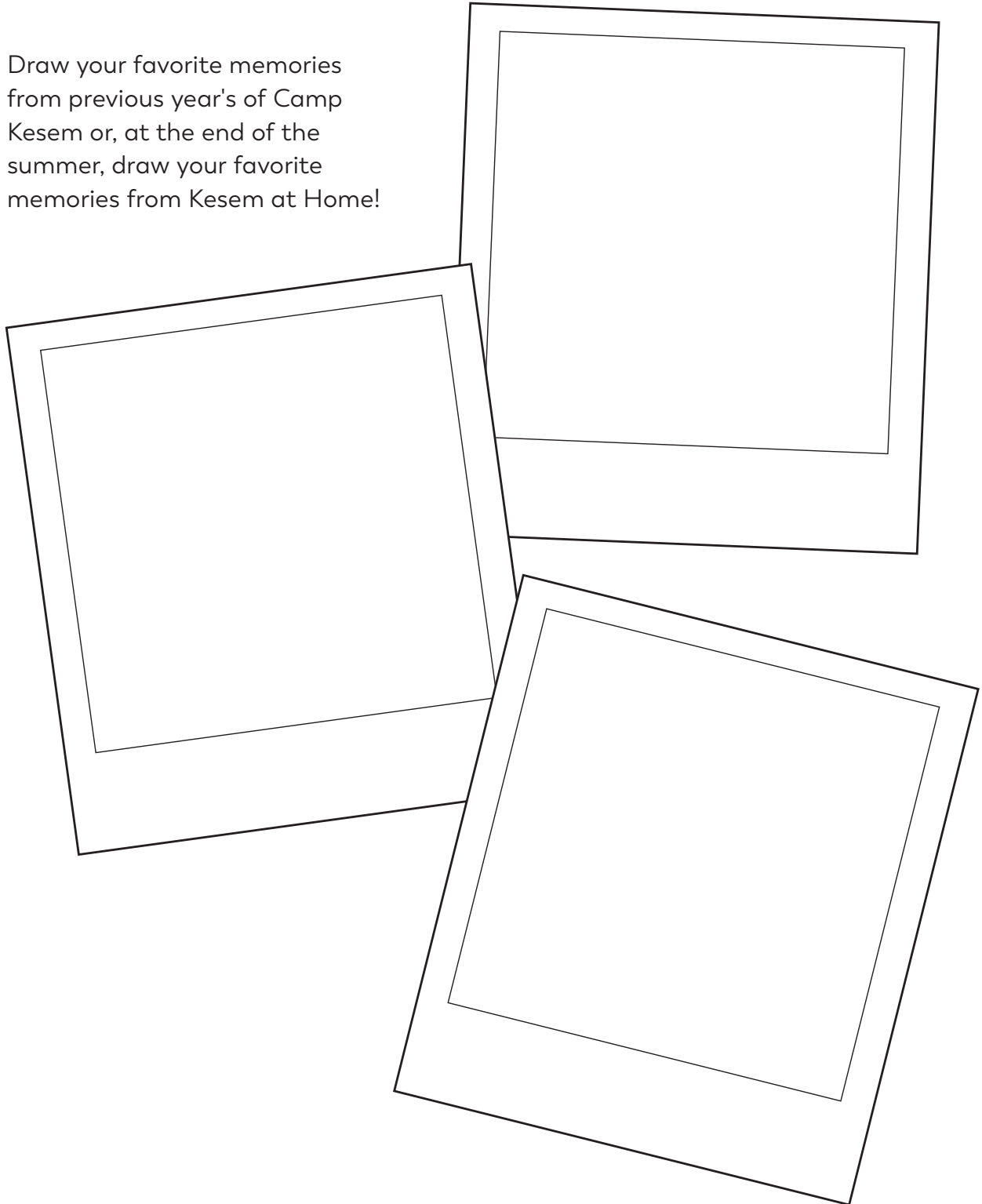

MAD LIBS ≡camp fancy≡

Ask your family or friends for words to fill in the blanks and then read the story aloud!

It was _____ . Finally, the time to dress up in my best
TIME

Camp Fancy gear. I couldn't _____ to show off my
VERB

_____ to my friends. My socks were striped _____
NOUN COLOR

and _____ to match my _____. I even wore a crazy
COLOR NOUN

_____ on my head to show off my Kesem spirit! It was the
NOUN

_____ outfit - nothing could make me more _____.
ADJECTIVE EMOTION

The best part? I had done a _____ job matching
ADJECTIVE

everything together! I knew my _____ would be the
NOUN

fanciest around.

MAD LIBS ≡camp fun≡

Ask your family or friends for words to fill in the blanks and then read the story aloud!

_____ and _____ loved camp. It was so
NATURE NAME 1 **NATURE NAME 2**

_____! They couldn't wait to finally _____.
ADJECTIVE **VERB**

All of their friends were _____, which meant there was
ADJECTIVE
never a boring _____.
PERIOD OF TIME

Sometimes, they would race each other. _____ was
NATURE NAME 1

as fast as a(n) _____! _____ was as fast as
ANIMAL **NATURE NAME 2**

a(n) _____. They never knew who would _____.
OBJECT **VERB**

It was always fun to sing together, too! They would _____
VERB

and _____ around the _____ every night. It
VERB **OBJECT**

was reason # _____ why camp was so _____.
NUMBER **ADJECTIVE**

MAD LIBS ≐make a splash≐

Ask your family or friends for words to fill in the blanks and then read the story aloud!

Yesterday, _____ and I traveled to _____ .
NATURE NAME PLACE

It was tradition to visit every _____ with all of our friends.
SEASON

Our favorite part was when everyone would swim in the
_____ together. We loved to pretend that we had our
NOUN
very own _____ .
NOUN

"Come on," I said. " _____ with me!"
VERB

_____ followed me into the _____ .
NATURE NAME NOUN

Not to brag, but we were both _____ swimmers!
ADJECTIVE

Together, we swam with our friends until we all felt _____ .
EMOTION

It was a day I would never _____ .
VERB

KESEM **≡bingo≡**

Description: Below are some common Kesem activities, cross off all of the actions you have completed with Kesem or outside of Kesem.

SELECTED A KESEM NAME	PUT ON BUG SPRAY	ENJOYED A S'MORE	WENT FOR HIKE/WALK	HAD AN EXTRA DESSERT
CREATED A NEW MEMORY WITH FRIENDS OR FAMILY	MADE A NEW KESEM FRIEND	COUNTED DOWN THE DAYS UNTIL KESEM	SAT AROUND THE CAMPFIRE	WORE A CAMP KESEM SHIRT
MADE A TIE-DYE SHIRT	PERFORMED A TALENT	 camp kesem. FREE SQUARE!	SANG A CAMP SONG	SIGNED A FRIEND'S SHIRT
PARTICIPATED IN A KESEM EVENT	PARTICIPATED IN CABIN CHAT	TAUGHT SOMEONE A CAMP SONG	TOOK A NAP DURING REST HOUR	MADE A NAMETAG
PARTICIPATED IN MESSY GAMES	WENT KAYAKING OR CANOEING	GOT TO GET FOOD FIRST DURING A MEALTIME	HAD A SLEEPOVER	WENT SWIMMING
PUT ON SUNSCREEN	MADE A FRIENDSHIP BRACELET	CHUGGED YOUR WATER	WATCHED A KESEM VIDEO	WROTE A LETTER TO A FRIEND



KESEM =bucket list=

Description: Bring camp into your home by completing this bucket list of camp activities this summer with your friends and family! Feel free to add your own based off of your camp favorites!

- ★ Check-In: Help your family or friends create their own camp name tag
- ★ Name Tag: Wear your name tags in public (to the store, park, etc.)
- ★ Campfire Stories: Share special memories or spooky stories around the campfire with your friends and family
- ★ Spirit Day: Dress your friends and family up in their best Kesem gear or unit color
- ★ Free Play: Host a free play period with your family; basketball, soccer, dance--it's your choice!
- ★ Mealtime: Set the table before a meal
- ★ Camp Songs: Teach a camp song (or five) to your friends and family
- ★ Rest Hour: Relax quietly in your bed for one hour in the afternoon
- ★ Snack Time: Help distribute snacks/to your friends/family
- ★ Water Break: Drink a glass of water every hour of the day
- ★ Mealtime: Clean up the table after a meal
- ★ Cabin Chat: Host/participate in a cabin chat with your friends/family
- ★ Empowerment: Host an Empowerment Ceremony with your friends or family
- ★ Dance Party: Play your favorite songs and dance the night away
- ★ Curfew: Make sure lights are out by 10:00 PM

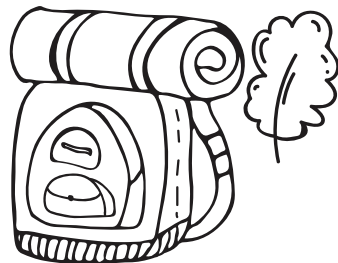
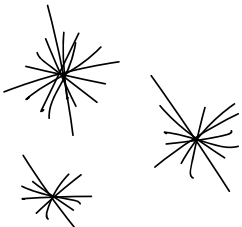

Fortune Teller

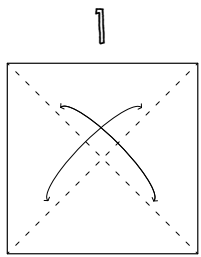

1
Cut out square & turn paper over. Fold diagonally in both directions, then unfold.

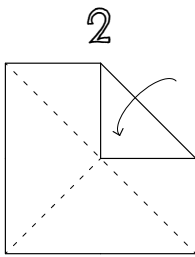

2
Fold each corner in to the center.

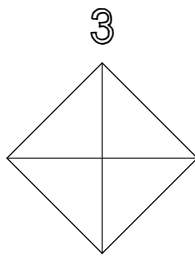

3
Flip the square over.

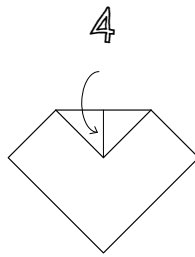

4
Fold each corner in to the center.

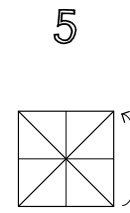

5
Fold in half both ways.

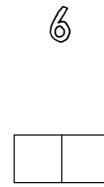

6
Put your fingers into each of the 4 quadrants.

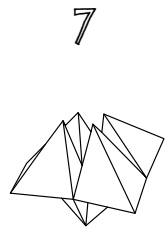

7
Pinch your fingers together!



≡WRITE YOUR OWN POETRY≡

ACROSTIC POEM WRITING

Description: In an acrostic poem, the subject of the poem is written vertically. Each letter in the subject is the first letter of each line. The lines of an acrostic poem can be a word, phrase, or sentence. Use the words below to create your own Kesem-themed acrostic poems!

K
E
S
E
M

M
A
G
I
C

C
A
M
P

Create your own using your camp name below!

HAIKU POEM WRITING

Description: A haiku is a Japanese form of poetry that is beautifully descriptive and often describes nature and the seasons. Use the space below to create your own Haiku about summer! (Tip: find the number of syllables in a word by humming the word and counting the number of hums.)

5 syllables

7 syllables

5 syllables

Karl's Crown

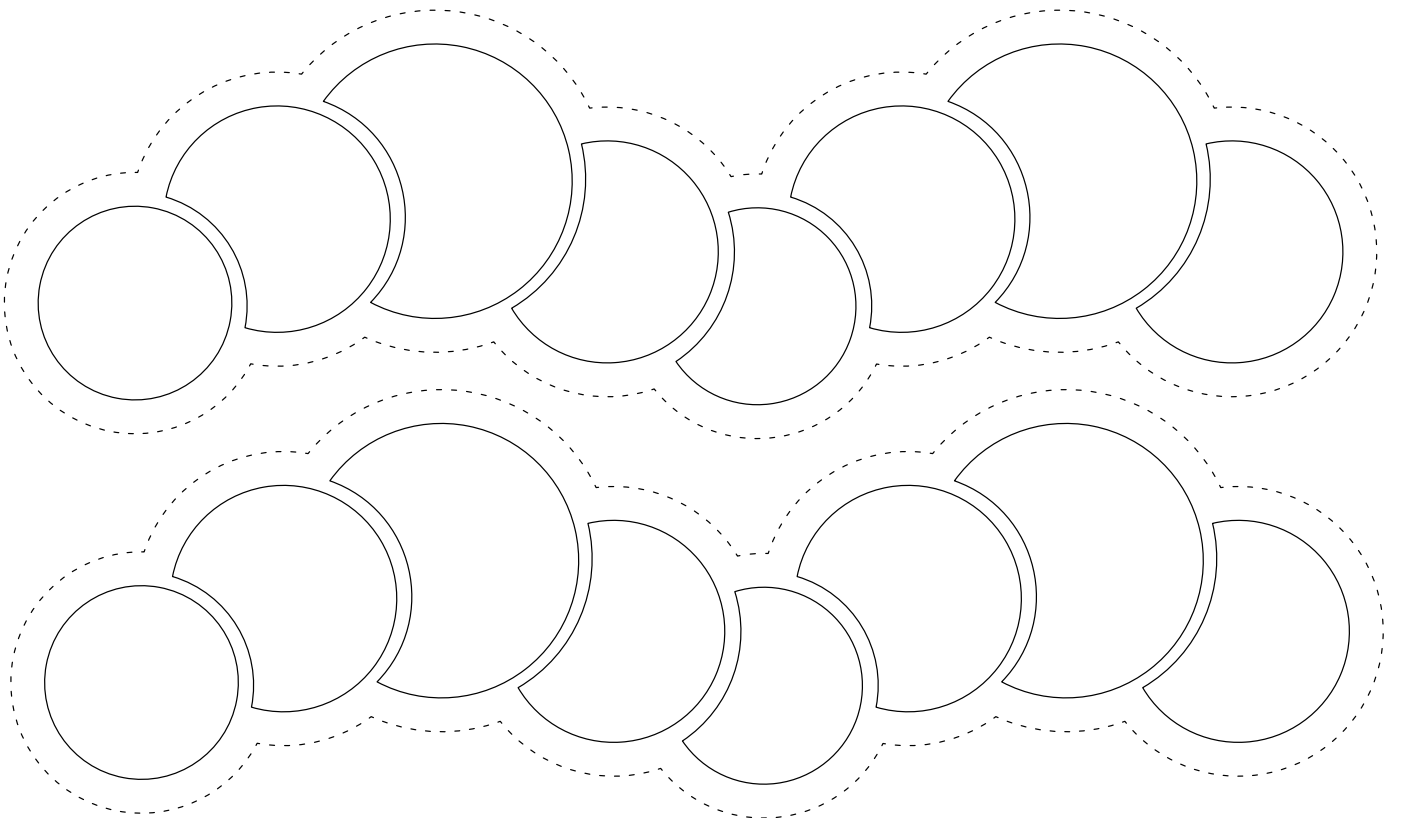
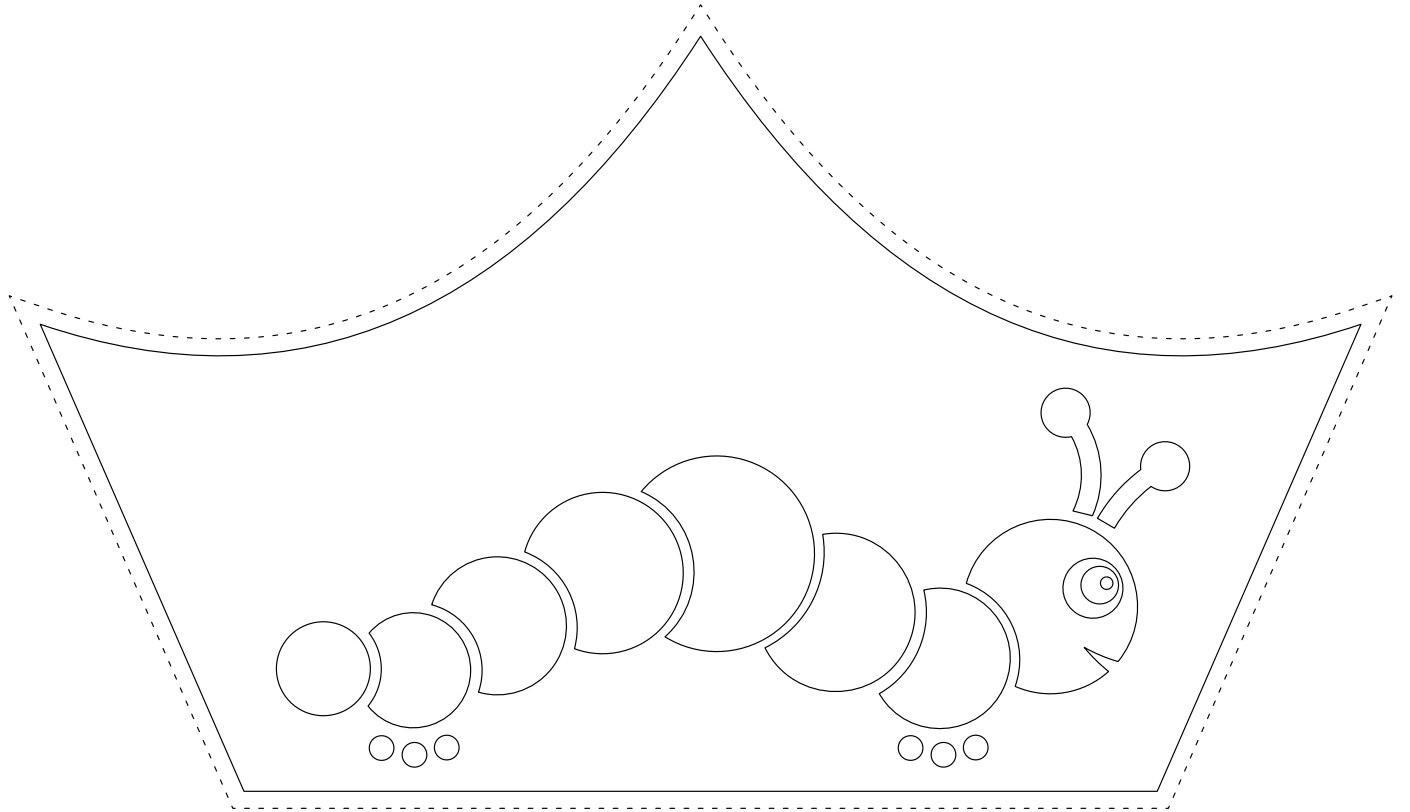

CRAFT =campfire=

Build your own miniature campfire! Color the shapes before you cut them out. Then lay the logs down flat, and assemble the fire on top by slotting the two halves together.

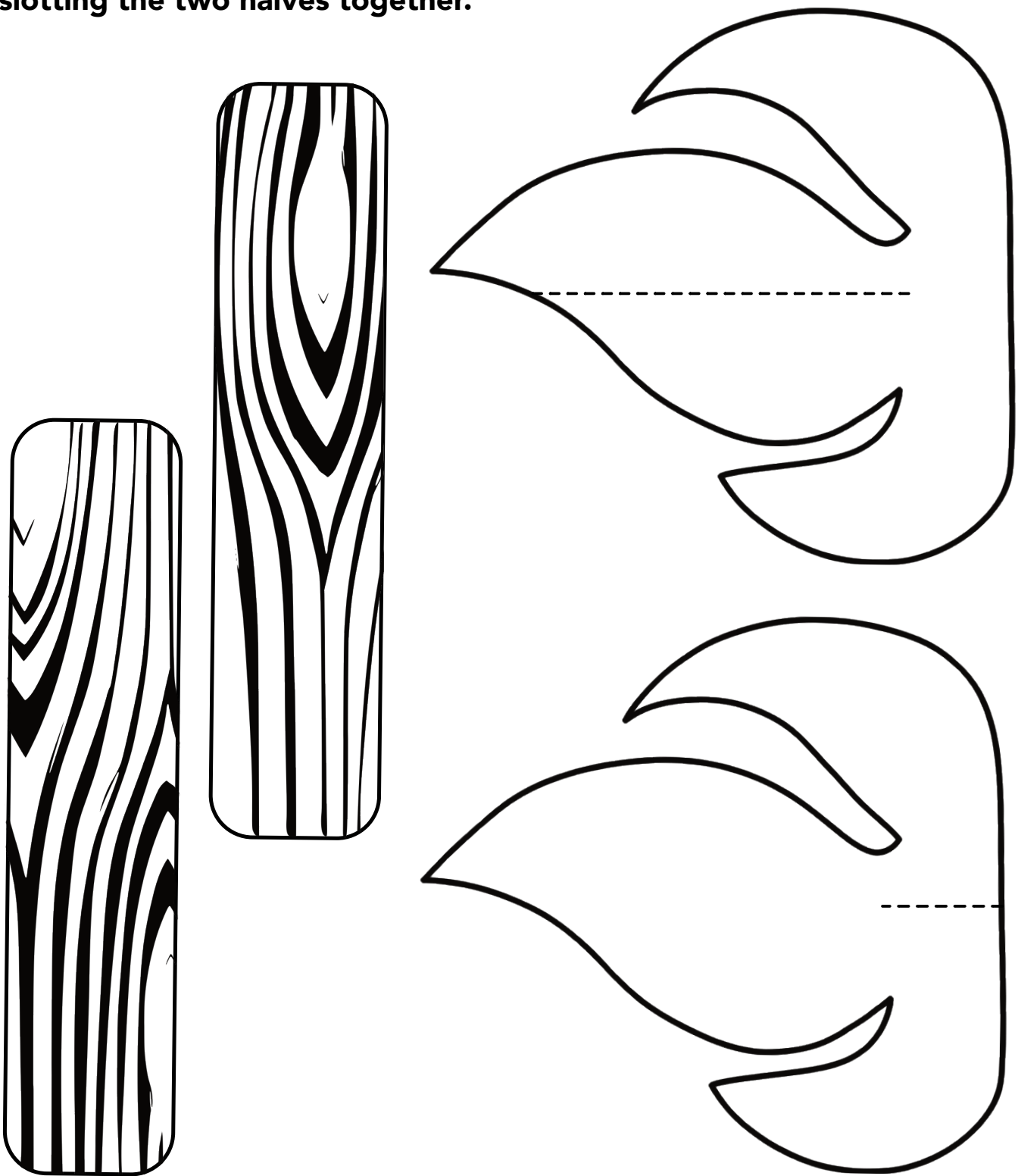

CRAFT ≡ paper airplane ≡

Construct an airplane in 7 easy steps!

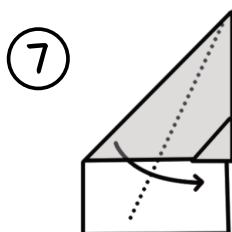
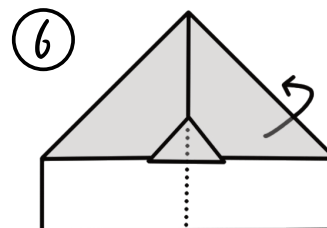
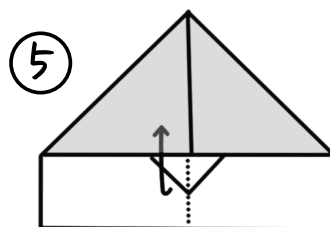
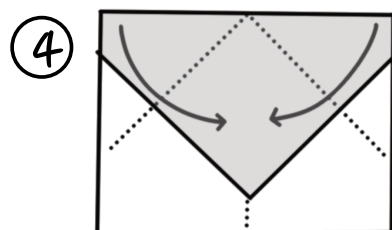
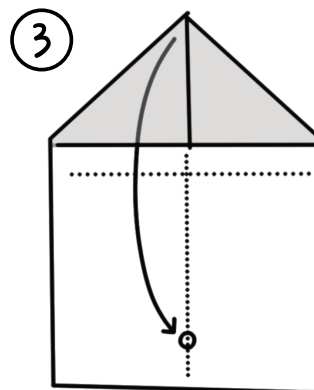
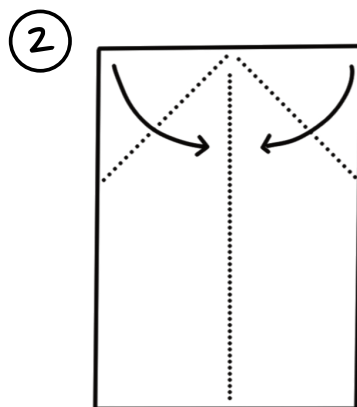
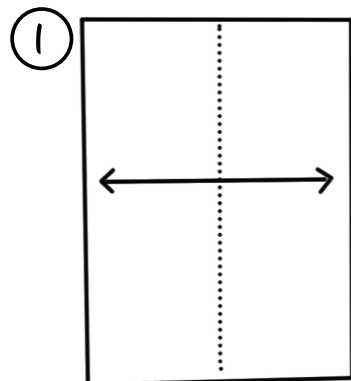
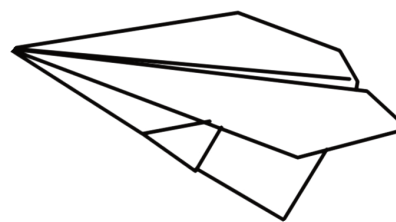

COMPLETE!

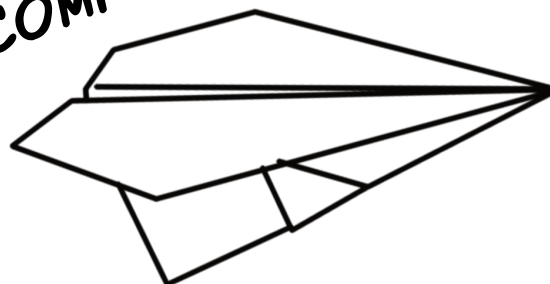

CRAFT ≡ paper bracelets ≡

Construct a paper bracelet in 5 easy steps! You only need 16-22 strips of paper, sized 12cm x 3cm.

- ① Fold every strip of paper in half, then in half again.

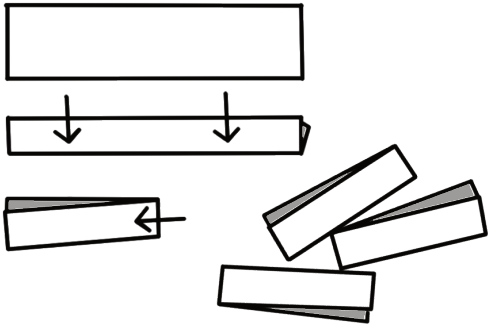

- ② Slip one folded piece inside another. Fold one half of the tail of the inside piece up at a right angle. Then fold it up, on top of the outer strip. Turn it over and repeat. You can secure the ends with a piece of tape.

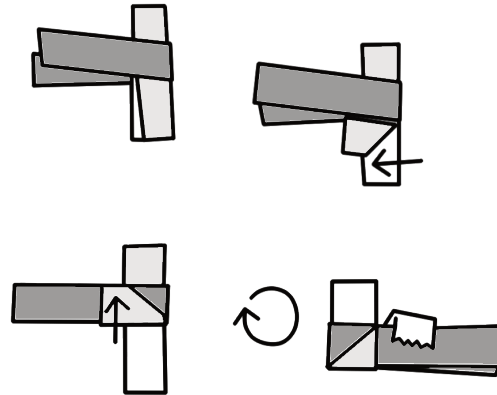

- ③ Add a new strip through the loop to make another loop. (It should be larger than the width of your strips!) Repeat the previous step, and tuck the folded tail into the pocket made from the previous strip. Turn to the right before adding the next strip.

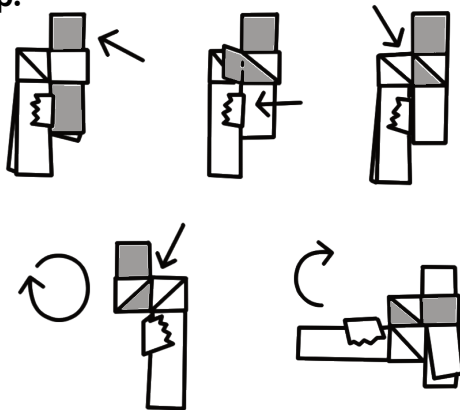

- ④ Continue adding strips until the bracelet fits around your wrist.

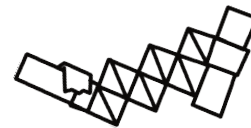

- ⑤ Remove your tape and bring the ends of your chain together by slotting the first strip into the last loop. Tuck the tails into a pocket and you're done!

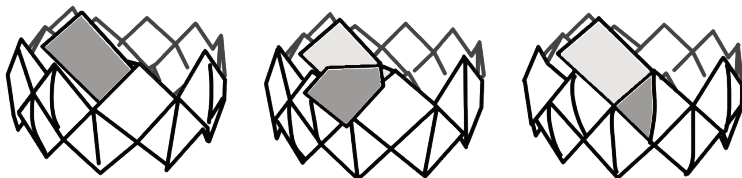

MESSY GAMES ≡painting edition≡

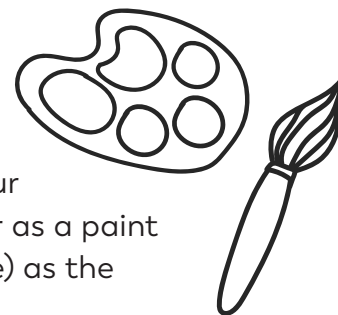

















Description: Rip this page out, so you don't get your book messy. Find your favorite messy materials and plop them right on the paper. Use the paper as a paint palette, the messy materials as your paint, your fingers (or something else) as the paintbrush, and a piece of paper as your canvas.

Sample Items: mud, toothpaste, dryer lint, shaving cream, ink and water, grass clippings, glue, slime, dirt, paint, shampoo, food coloring, nail polish, or any other messy substances you have!

INTENTIONAL BLANK PAGE

SCAVENGER HUNT

Description: Using the prompts below, turn this page into your very own custom scavenger hunt. Feel free to get creative with this - this is your masterpiece!

-  Spell your Kesem name out at the top of this paper using magazines, newspapers, and other pre-printed media.
-  Draw pictures of or write the names of your favorite camp activities on the top right corner of the page and circle them.
-  Find two things: one that starts with the letter C and one that starts with the letter K.
-  Draw the two objects to the right of the word Hunt above.
-  Grab an object that best embodies the spirit of Kesem. Write what the object is above the number.
-  Write the name of an object you'd want to repurpose for camp above the Next Steps box, and write the object's new purpose under the box.
-  Find a Post-It note. Write one thing you're grateful for on the back of it and stick it to this direction, so that nobody else can read it.
-  Grab an orange object in your home and try to draw it on top of all of these directions without looking at the paper.
-  Get your favorite color and highlight every C and every K that appears in these directions.
-  Grab a snack you wouldn't normally eat and write the name of it next to this direction.
-  Put a sock on your hand and try to write "You can't ride in my little red wagon!" at the bottom of this page.
-  Find a rock outside and make it your pet rock by drawing a face on it with a pencil or marker and giving it a name.
-  Flip any book to a random page. Point to a random word on the page. Write that word to the right of the last word of this sentence.
-  Write the color of the first shirt you find in your room on the Post-It note you stuck to this page.
-  Using your least favorite color, color the Description box, and color every 3 boxes the same color.
-  Draw a star in the box of your favorite direction, and cross out the one you liked the least.
-  Grab a piece of clear tape and stick it across this entire page to mark it as complete!

Next Steps: Tell a story to a Kesem friend or a family member using the names of the objects you wrote on the page!

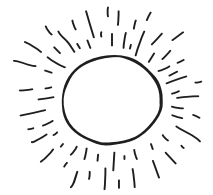

KESEM RIDDLES

Description: How many of these Kesem-themed riddles can you answer correctly? Make your guesses and then quiz your friends and family with these brain-teasers!



Q1: What belongs only to you, and yet is used more by others than by yourself?

Q2: What part of Montreal is in Kesem?

Q3: I have keys but no doors. I have space but no rooms. I allow you to enter, but you are never able to leave. What am I?

Q4: What starts with a “t”, ends with a “t”, and is full of “t”?

Q5: Take away my first letter and I am a store.

Take away the second and people who look at me adore.

Put all my letters back and read me in reverse if you are able.

I am now cars suspended from an overhead cable.

Take a letter away and I become a male sheep.

What word am I?

Q6: I’ll always walk beside you
And be the friend you need
You’ll think of me when you see caterpillars,
Or the colors blue and green!
If you ever want to see me,

Just look up above

We’re all under the same moon and stars
Connected by Kesem love

What am I?

Q7: I am a seed with three letters in my name. Take away the last two and I still sound the same. What am I?

Q8: What do peanut butter and jelly do around the campfire?

Q9: You make me at the start of camp
And wear me every day
Even during swimming time,
I’m never far away
I make it through the Messy Games
And all of the campfire nights
I’m even right beside you
When your counselor turns out the lights
What am I?

Q10: I am more hot than cold, more soft than prickly, and all who receive me feel joy quickly. What am I?

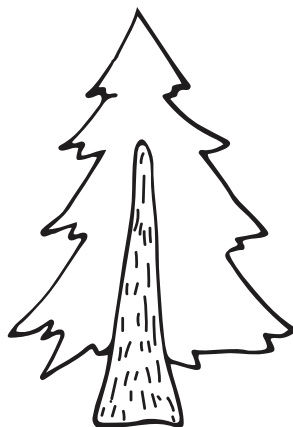

A1: Your Kesem name! A2: M A3: A keyboard A4: A teapot A5: Smart A6: Your Kesem family <3 A7: A pea A8: They tell toast stories. A9: Your name tag! A10: Warm fuzzies!

KESEM BRACKET

Choosing the best part of camp is hard - which activity will earn it's spot as your ultimate favorite?

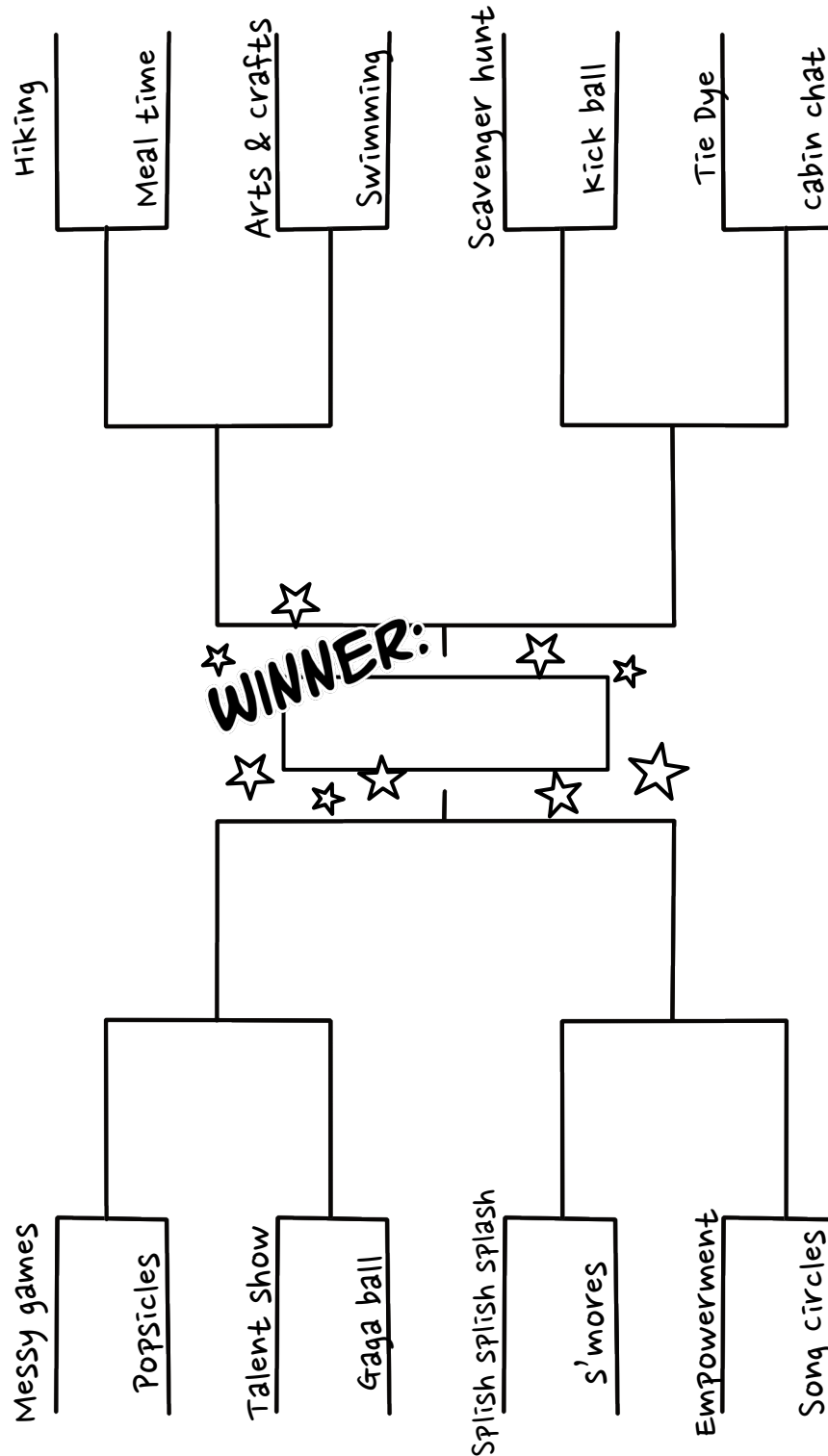

KESEM TRIVIA

Description: Are you a Camp Kesem expert? Test your knowledge of all things Camp Kesem by answering the questions below!

What year was Camp Kesem founded?

What is Camp Kesem’s “mascot’s” name?

How many states have Camp Kesem chapters?

What is Camp Kesem’s mission statement?

What are Kesem’s core values?

This year is Kesem’s 20th Anniversary; what is Kesem’s 20th Anniversary theme?

What are the four pillars of Kesem’s Empowerment Program?

How many campers attended Camp Kesem in summer 2019?

How many millions of children are affected by a parent or guardian’s cancer in the U.S.?

How many Camp Kesem chapters are in the United States?



Next Steps: Go test your family’s knowledge of Camp Kesem by asking the questions above!

Answers: 1. 2000; 2. Karl the Caterpillar; 3. 44; 4. A nationwide community, driven by passionate college student leaders, that supports children through and beyond their parent’s cancer; 5. We are optimistic, we leave a lasting and positive impact, we empower others, we care deeply about the work we do, we are grateful; 6. Shine On; 7. Tone Setting, Sharing & Reflection, Warm & Fuzzy, Empower-Hour; 8. 10,266; 9. Over 5 million; 10. 125

PICTIONARY

Setup: This game requires at least 4 people, split into two teams. The teams don't have to be the exact same number of people if you have an odd number of people. Cut out the clues below, fold each clue in half, and put them all in a bowl.

Materials: Paper, pencil, scissors, bowl, timer, something to write on (large paper pad, chalkboard, whiteboard, blank paper, etc.)

Description:

Divide into at least 2 teams of at least 2 players

Pick a scoring goal (10 points, 30 points, or 50 points)

Pick a team to go first (Rock-Paper-Scissors or flip a coin to decide)

The team that goes first will decide on one player to be the "Artist"

Set the timer to 60 seconds

When the Artist is ready, start the timer

The Artist picks a clue randomly from the bowl and begins drawing the clue

The Artist may not make any sounds or gestures or draw any letters or numbers

Score 1 point for a correct guess, and keep going until the timer runs out

Rotate teams until the scoring goal is met

The first team to meet the scoring goal wins

If team 1 wins on their turn, team 2 should get a chance to beat their score

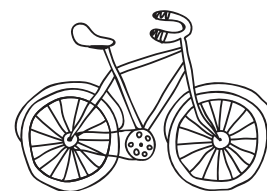

Tips:

To extend the game, you can choose to play more than 1 game. For example, best 2 out of 3 games, or best 3 out of 5 games, etc.

Once you have used all the clues below, feel free to make your own clues!

Try making up clues with specific categories, or make up harder clues to draw

Try changing the time limit or switching up teams

Make up your own rules!

CAT	BUG	TREE	COAT	HOUSE	SHIRT
SUN	BOOK	SOCKS	HEART	TENT	WHALE
CUP	PLATE	SHOES	HAT	MOUSE	BEACH
GHOST	FORK	SMILE	OCEAN	HORSE	HIPPO
FLOWER	SPOON	WATER	KITE	LION	EGG
SNOWFLAKE	LIGHTBULB	SHOELACE	DUCK	SKATEBOARD	COOKIE
CAKE	PIE	BOAT	EYES	TIGER	KING

QUIZ ≡ which essential camp equipment are you? ≡

Description: Answer the questions below. Then, use the key to discover which essential camp equipment you are!

What is your favorite type of movie or show?

- a) Action b) I love all movies! c) Drama d) Comedy

What is your dream job?

- Firefighter b) Artist c) Scientist d) Not sure!

How would your friends describe you?

- a) Leader b) Thinker c) Mediator d) Comedian

If you had one day all to yourself, how would you spend it?

- a) Going to an local museum, concert, or event
b) Writing in my journal and talking with friends
c) Enjoying some peace and quiet on a hammock
d) Hiking, biking, running, sports

What is your ideal pet?

- a) Horse b) Cat c) Dog d) Parrot

What is your favorite subject in school?

- a) Math b) Art c) Science d) English

What do you think is your best quality?

- a) Your confidence b) Loyalty c) Keeping the peace d) Your sense of fun!

What is your favorite Kesem activity?

- a) Singing songs b) Arts & Crafts c) Empowerment d) Messy Games

If you answered with mostly A's....

You got **S'MORES!**

You are powerful, action oriented, and in charge. You are a natural leader who works hard and always gets things done. Your friends can always count on you to step up and take action when someone needs help.

If you answered with mostly B's....

You got a **HAMMOCK!**

You are creative and introspective. You are so great at thinking about things in your life that you are always daydreaming. Others can always count on you to come up with new and creative ideas!

If you answered with mostly C's....

You got **SLEEPING BAG!**

You are peaceful, calming, and patient. When other people fight, you'll do anything to keep the peace. You always keep a level head and can calm down when you are angry or upset.

If you answered with mostly D's....

You got **FLASHLIGHT!**

You are attention grabbing and fun loving! You love to be the center of attention and make other people laugh. You are always up to try something new and exciting!

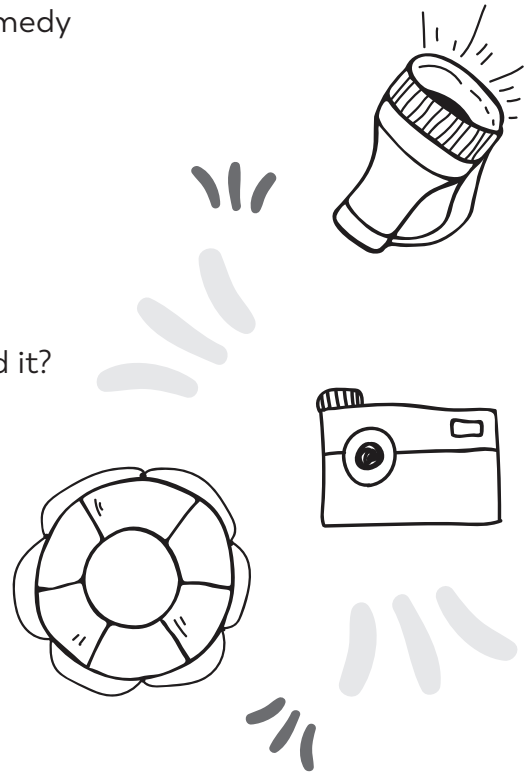

How to make an Origami Heart!

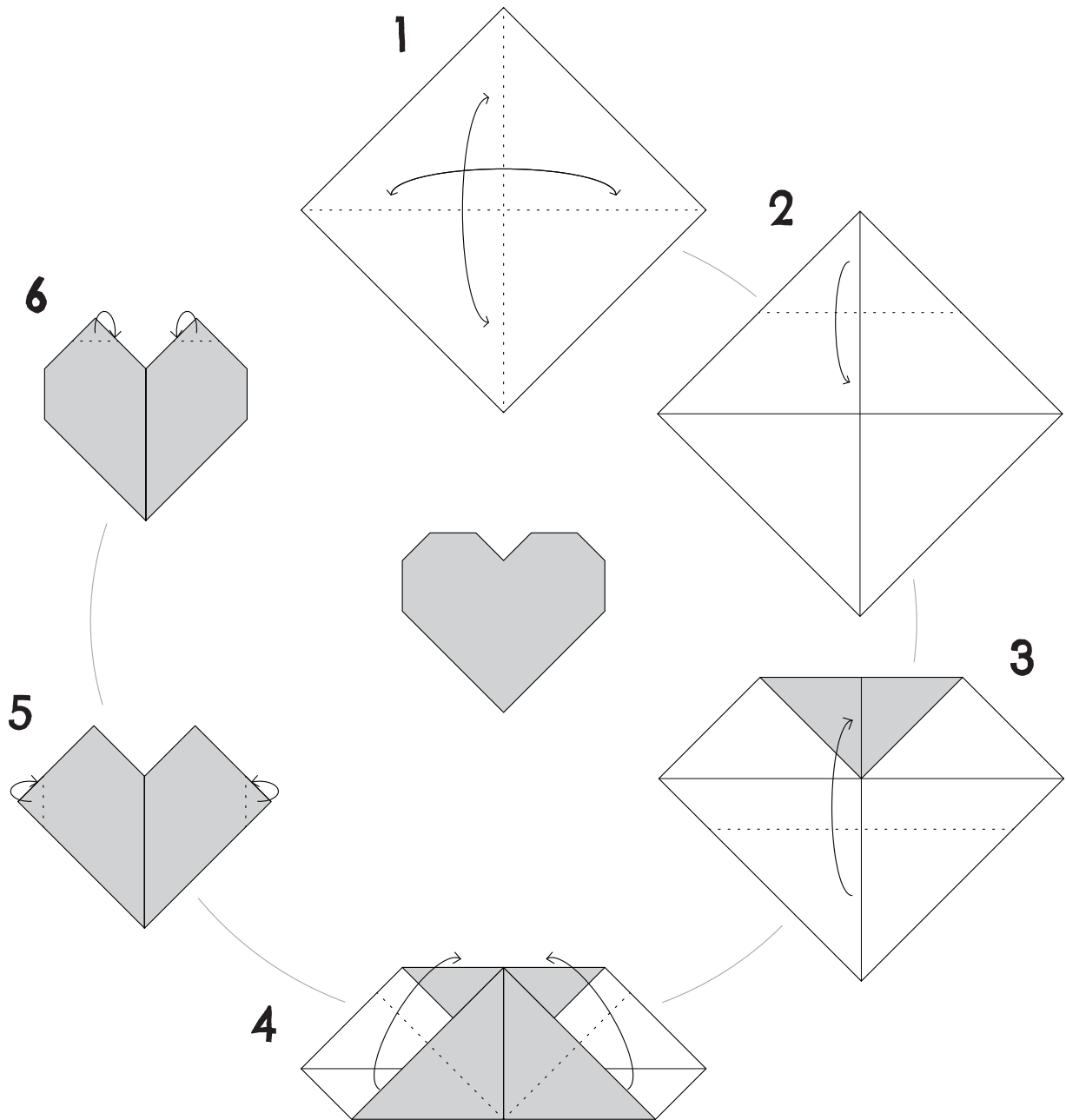

COUNSELOR SCAVENGER HUNT ≡board 1≡

Description: You are a Unit Leader at camp and you need to round up your counselors! Draw each group of counselors in the grid below to represent your units. Take turns guessing which box your opponent's units are in by calling out coordinates (eg D5). The opponent responds with "spotted" if it's on one of your units or "miss" if it misses. Once the last counselor in a unit is found, the opponent must announce the name of the unit ("You found __ unit".) Record your opponent's guesses on the top grid, and yours on the bottom grid as "X" for a spotted camper and "O" for a miss.

A							
B							
C							
D							
E							
F							
	1	2	3	4	5	6	7

MY COUNSELORS



Red Unit



Blue Unit



Teen Unit

OPPONENT COUNSELORS



Green Unit



Yellow Unit



Teen Unit

A							
B							
C							
D							
E							
F							
	1	2	3	4	5	6	7

COUNSELOR SCAVENGER HUNT ≡board 2≡

Description: You are a Unit Leader at camp and you need to round up your counselors! Draw each group of counselors in the grid below to represent your units. Take turns guessing which box your opponent's units are in by calling out coordinates (eg D5). The opponent responds with "spotted" if it's on one of your units or "miss" if it misses. Once the last counselor in a unit is found, the opponent must announce the name of the unit ("You found __ unit".) Record your opponent's guesses on the top grid, and yours on the bottom grid as "X" for a spotted camper and "O" for a miss.

A							
B							
C							
D							
E							
F							
	1	2	3	4	5	6	7

MY COUNSELORS



Red Unit



Blue Unit



Teen Unit

OPPONENT COUNSELORS



Green Unit



Yellow Unit



Teen Unit

A							
B							
C							
D							
E							
F							
	1	2	3	4	5	6	7

Next Steps: Create your own custom "Battleship"-style game on a separate sheet of paper and play with your friends or family!

D.I.Y VISION BOARD

Description: A vision board is a collage of images and words that inspires you and leaves you feeling happy. Using the guidance below, build your very own vision board!

Remember to choose words and images that spark joy, inspire you, and motivate you to achieve your dreams! Then, find a space to hang it up where you can see it every day!

EXAMPLE: KARL'S VISION BOARD



QUESTIONS TO GUIDE YOUR VISION BOARD

- What motivates you? What inspires you?
- What brings you joy?
- What are your values?
- What are my strengths?
- Where do I feel safest?
- What am I grateful for?
- What do I look to do? What new activities am I interested in or willing to try?
- Who or what gives me comfort?
- When I'm feeling down, I like to ___
- What is my favorite movie? Book? Animal? Color?
- What do I do to show myself compassion?
- What do my dreams tell me?
- What is my happiest memory?
- What do I value most in a friend?

MATERIALS TO USE

- Paper/poster
- Tape
- Scissors
- Photos
- Magazine clippings
- Newspaper clippings
- Stickers
- Quotes
- Postcards
- Keepsakes from camp, school, travel, etc.
- Mementos that inspire you!

Next Steps: Share your vision board with your family or friends and explain to them why you chose each item on your board. Encourage your family and friends to make a dream board, too. Remember to reflect on your dream board whenever you are feeling down or struggling to overcome a challenge, and keep adding to your dream board!

LEADERSHIP DEVELOPMENT ≡interview practice≡

Description: Asking thoughtful questions and being a good listener is a beneficial skill to have in any stage in your life--and the more you practice these skills, the better you will get at them! Using the tips and sample questions below, organize an interview with someone in your life.

INTERVIEWING TIPS

Asking Good Questions

A good question will get someone thinking, and invite them to talk openly. “Yes or no” questions will not make for an interesting conversation or interview. Think about open-ended questions that will spark a story or conversation. Start questions with “why”, “how”, “tell me about”, etc.

Finding a Subject

Identify someone in your life you want to know more about, someone you look up to, someone with a skill you aspire to improve, or someone you think is interesting. Ask them if you can interview them in-person, over the phone, or over video. After interviewing them, think about someone you have never met that you would like to talk to, and try to reach out to them for an interview!

Preparing for an Interview

Write down some questions you would like to ask, and think about ways to ask follow-up questions:

“Interesting, can you talk more about that?”

“Why do you think that happened?”

“What was going through your head at that time?”

Have a notepad and pen ready to write down notes or more questions that come up, and ask your subject if they are comfortable being recorded before recording them.

SAMPLE QUESTIONS

- Can you tell me about your childhood?
 - What did you want to be when you were young?
 - What is something you loved to do when you were young?
 - How have things changed since you were young?
- What is something great you learned from your parents?
- What made you want to do the work that you do?
- What is something you believe that other people might think is crazy?
- If you could have a billboard that reached millions of people, what would it say?
- What is your favorite memory? Why?
- What do you wish you knew when you were my age?
- What is your most prized possession?
- How did you get to be where you are now?

LEADERSHIP DEVELOPMENT ≡F.O.T.A.Y.≡

Description: F.O.T.A.Y. stands for Figure Out The Activity Yourself. This will help you get creative and think on your feet. Being able to do this well can be a great tool for a camp counselor, or anyone!

1. **Search your house** (or surrounding area) and collect 6 items of varying size, shape, purpose, etc. and write them below in the “Items” section
2. **Get creative!** Invent a game or activity that you could teach to a group of campers, siblings, family members, friends, classmates, teammates, or anyone!
3. **Write down** the setup, how the game is played, and the rules of the game below
4. Once you have created the game, **teach** it to someone!
5. As you try teaching the game, think about what works well and what doesn't. You can always come back and change any part of the rules, **it's your game!**

ITEMS

1. _____
2. _____
3. _____
4. _____
5. _____

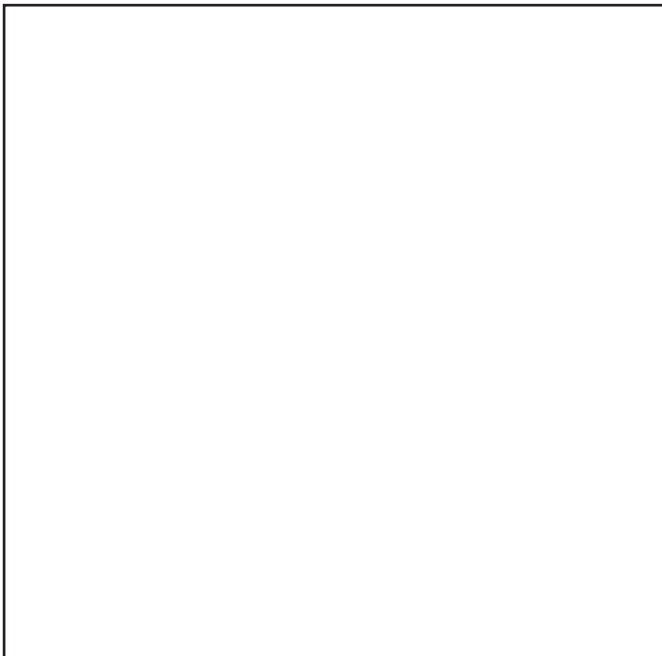

SETUP

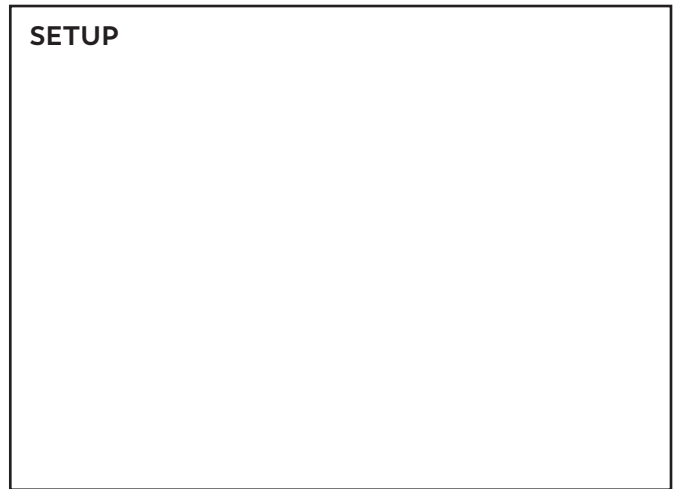

RULES

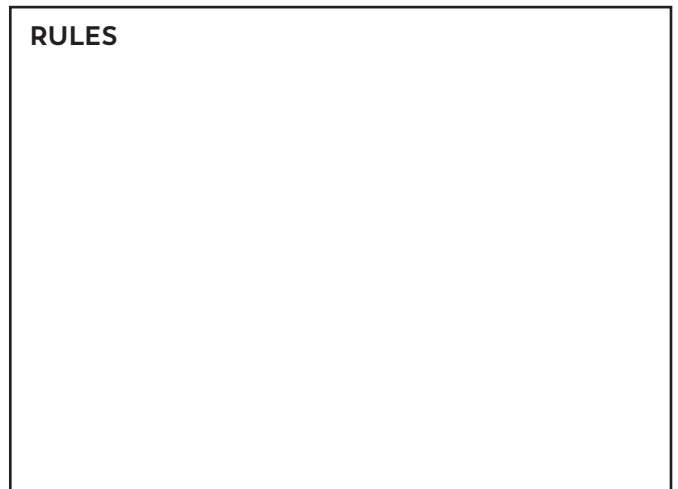

Debrief: What was the hardest part? What was the most fun? What could make this activity even better? What is one thing you learned?

The background is filled with various hand-drawn icons in a light gray color. There are several stars of different sizes and styles, some with outlines and some with solid fills. There are also hearts, some with radiating lines around them, and a simple cross. The overall style is casual and artistic, resembling a doodle or sketch.

EMPOWERMENT

EMPOWERMENT CEREMONY



Description: The Empowerment Ceremony is a time for campers and counselors come together to talk about the why behind coming together at Kesem in a supportive, empowering environment. The Empowerment Ceremony consists of four pillars, outlined below. Using the prompts below (or others), host your own ceremony with your family or friends!

PILLAR 1: TONE SETTING

Description Participants often have a lot on their mind going into Empowerment; this pillar is intended to create a calm, safe mood for everyone to share.

Programming Options

Guided meditation
Reflective art/coloring (see Activity Book pages!)
Sing a slow, calm camp song
Sit in a circle and “make rain” by having all participants follow one person’s lead. The first pass of the circle the leader rubs his/her hands together, second pass is snapping, third is clapping, fourth is patting hands against legs, then reversing back to rubbing hands together.

PILLAR 2: REFLECTION & SHARING

Description The heart of Empowerment - this gives campers the opportunity to talk about what Kesem means to them. The sharing portion often includes memories about our camper’s journey with cancer and how much Kesem has impacted them.

Sample Questions

How has Kesem impacted our family?

What words come to mind when thinking about the Kesem community?
What are we looking forward to most this upcoming year?
What has Kesem taught you?

PILLAR 3: WARM & FUZZY

Description Empowerment can bring a lot of feelings up, but we want them to walk away feeling stronger and supported so we encourage “warm-fuzzies” after sharing.

Programming Options

Write a letter to someone who has impacted you
Web of kindness - each person say something nice about a different participant

PILLAR 4: EMPOWER-HOUR

Description This piece of Empowerment is simply FUN! Find an energetic, uplifting activity to do with your family to end the ceremony on a high note.

Programming Options

Dance party
Song circle
Other games/activities in this book!

WORD SEARCH *≧empowerment≧*

U V A U X U I H B H I R K W B
B Z N M O K R U H T N Z E J X
A L G C B Q W P Y J S R S O R
M D N A E I C R V Z P O E F B
Z N X G X E M B I Q I O M P M
S Q U S C Y U C Z M R I S F A
J I N K Y P O U G V A Z I C G
K I O A I F L A R C T U J B I
I K S P I R I T N J I A H N C
N C Z D S F F D M O O B X L L
D P R C Z X A E A Y N I R L K
N D S F H U M S O A I R C P Z
E O S H A R I N G V T C Q V C
S V N C Z O L O V E I A T E A
S Z E D M A Y K H W V J T B S
M E D B I H D C H O P E W F L

Word Bank:

Family Joy Love Spirit
Hope Kesem Magic
Inspiration Kindness Sharing

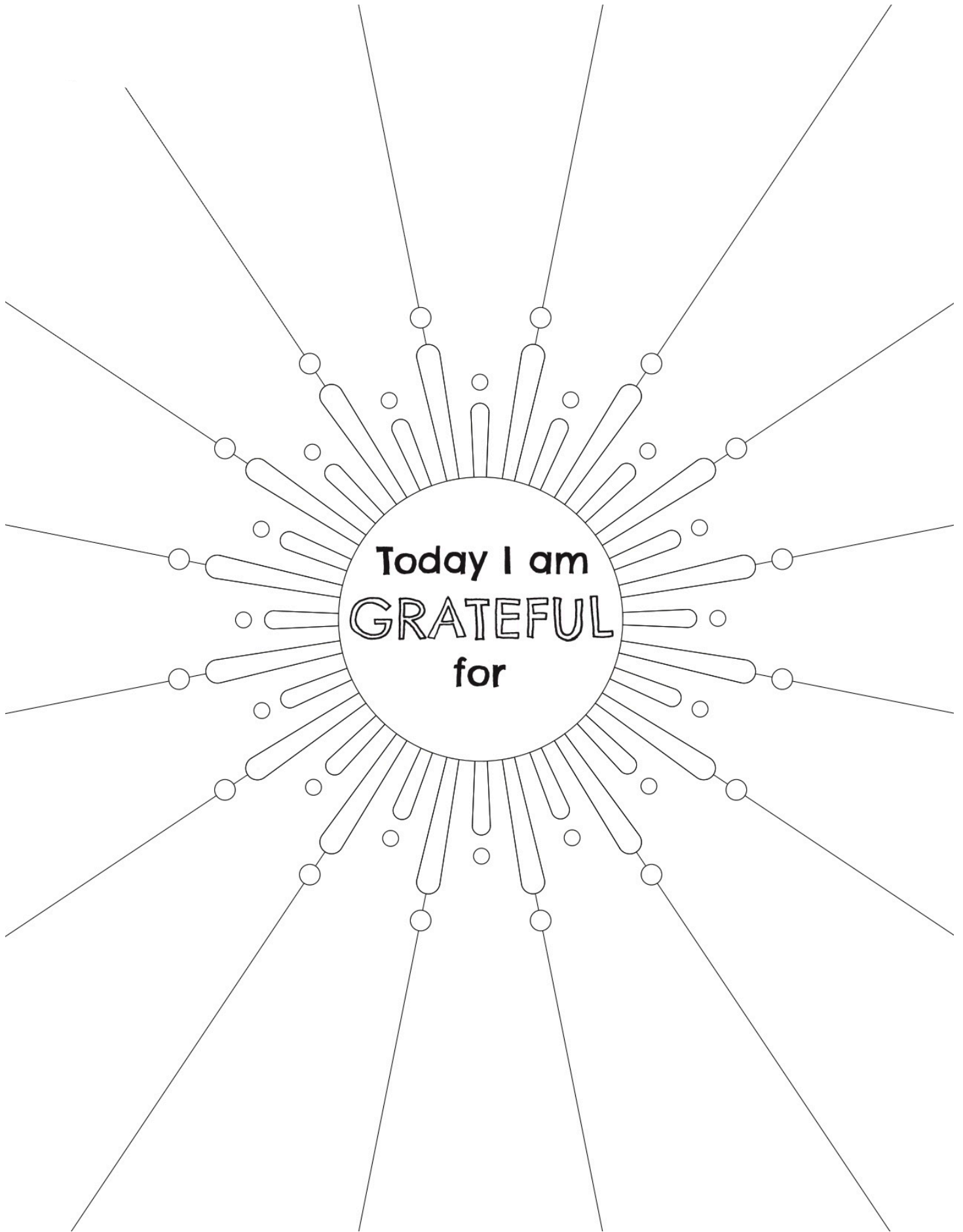

≡ GRATITUDE LETTER ≡

Description: Write a letter to someone you admire using the template below. Cut on the dotted line and give it to them!

Date: -----

----- (Greeting)

----- (Closing)

----- (Your Name)

INTENTIONAL BLANK PAGE

Yoga Bingo

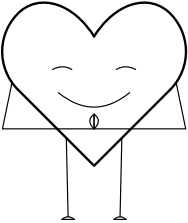
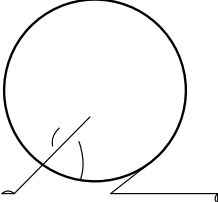
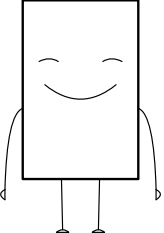
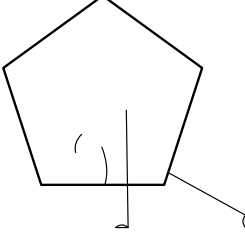
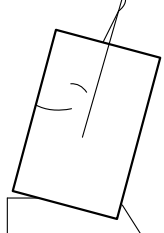
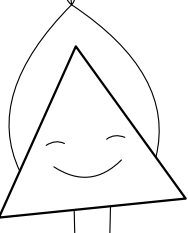
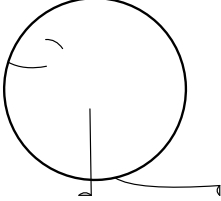
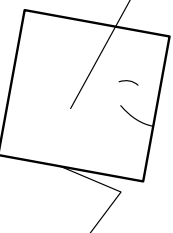
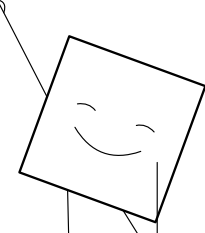
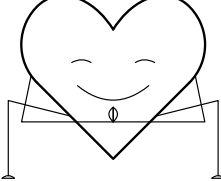
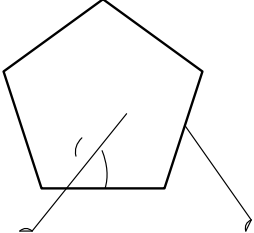
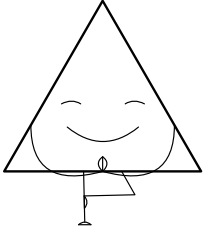
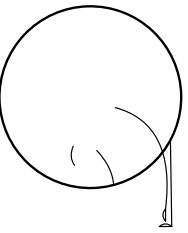
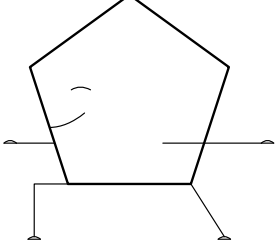
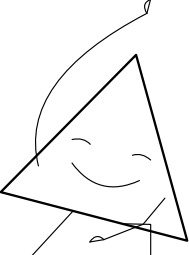
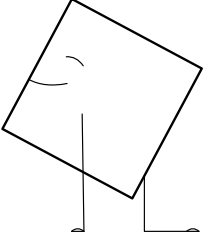
 <p>hands to heart</p>	 <p>child's pose</p>	 <p>mountain</p>	 <p>plank</p>
 <p>crescent lunge</p>	 <p>kite</p>	 <p>cobra</p>	 <p>chair</p>
 <p>triangle</p>	 <p>frog</p>	 <p>downward dog</p>	 <p>tree</p>
 <p>forward fold</p>	 <p>warrior</p>	 <p>side angle</p>	 <p>cow</p>

KARL AWARDS



Cut on the dotted line and decorate a certificate to give to a special person in your life!

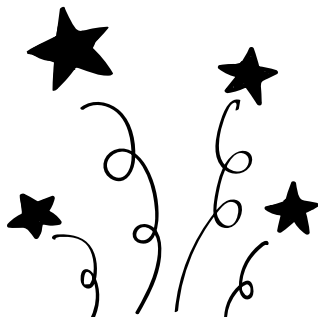

INTENTIONAL BLANK PAGE

KESEM FAMILY TREE

Spring is in full bloom! Engrave your name on the trunk, then draw a special flower in the tree for each member of your Kesem family.

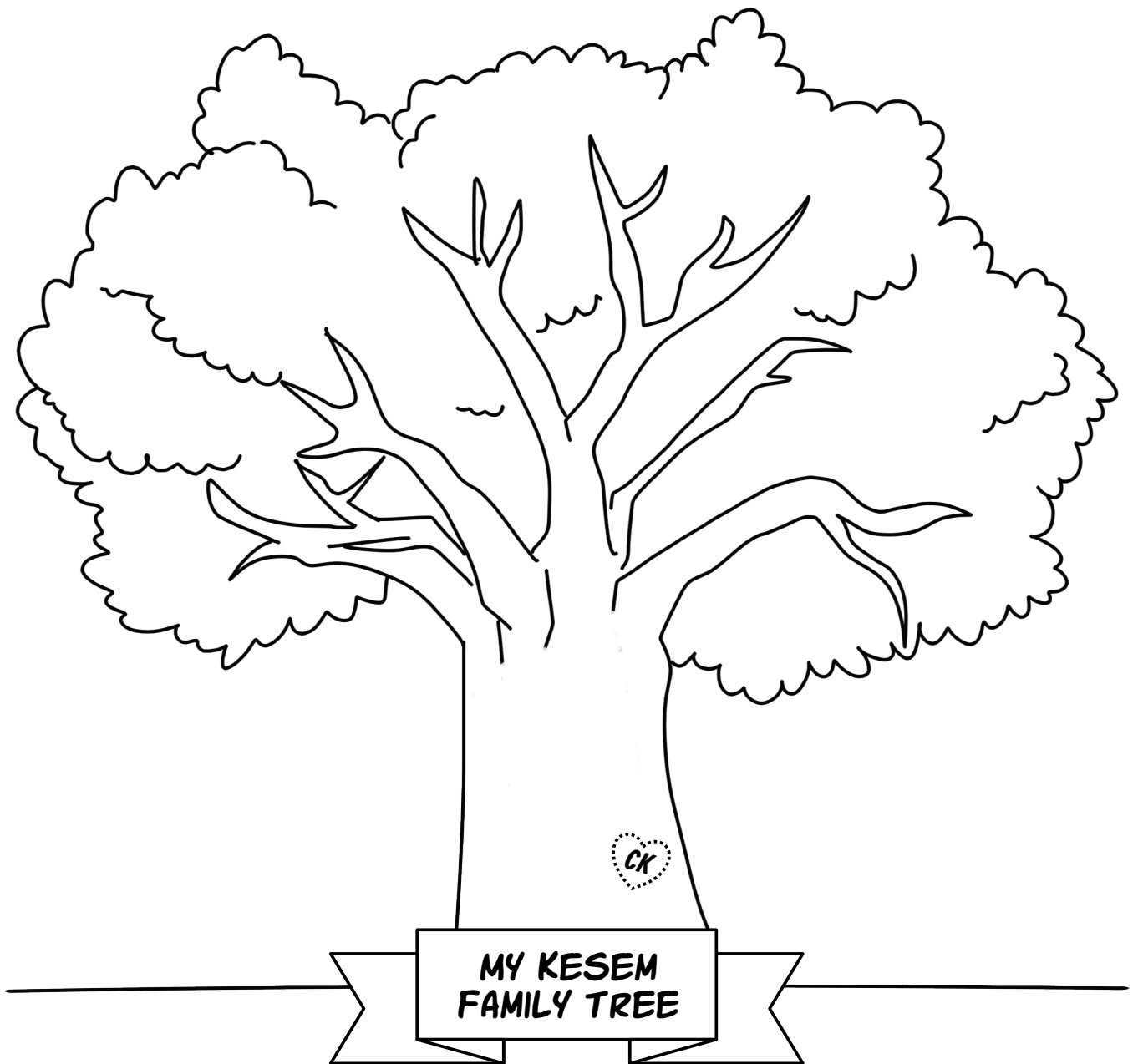

EMPOWERMENT ≡values exercise≡

Description: This worksheet will help you figure out what's most important to you. For each item, rank how important it is to you by filling in the circle (1 full circle = least important, 5 full circles = most important) and then use the following prompts to reflect on your results!

Having fun

○ ○ ○ ○ ○
1 2 3 4 5

Getting good grades

○ ○ ○ ○ ○
1 2 3 4 5

Spending time with family

○ ○ ○ ○ ○
1 2 3 4 5

Laughing

○ ○ ○ ○ ○
1 2 3 4 5

Trying something new

○ ○ ○ ○ ○
1 2 3 4 5

Being creative

○ ○ ○ ○ ○
1 2 3 4 5

Having a lot of money

○ ○ ○ ○ ○
1 2 3 4 5

Being a kind person

○ ○ ○ ○ ○
1 2 3 4 5

Being smart

○ ○ ○ ○ ○
1 2 3 4 5

Listening to others

○ ○ ○ ○ ○
1 2 3 4 5

Making people smile

○ ○ ○ ○ ○
1 2 3 4 5

Helping out someone in need

○ ○ ○ ○ ○
1 2 3 4 5

Having good friends

○ ○ ○ ○ ○
1 2 3 4 5

Feeling understood

○ ○ ○ ○ ○
1 2 3 4 5

Being popular

○ ○ ○ ○ ○
1 2 3 4 5

Which values did you rate as most important?

Why do you think this value is important to you?

What is one way you could apply this value to your summer?

Next Steps: Ask your family to fill out this sheet for themselves. See if you notice any similarities!

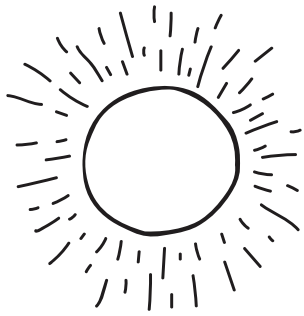

SUMMER

≡in review≡



KESEM CHAPTER:

UNIT/CABIN:



≡FAVORITES≡

≡Would YOU RATHER?≡

COLOR: -----

Messy GAMES OR TALENT SHOW?

ACTIVITY: -----

DANCE PARTY OR SONG CIRCLE?

CAMP SONG: -----

CABIN CHAT OR EMPOWERMENT?

CAMP FRIEND: -----

ARTS & CRAFTS OR SPORTS?

COUNSELOR: -----

----- OR -----

MEMORY: -----

----- OR -----

